

PAPER • OPEN ACCESS

## Experience in effective changing of the tunneling parameters according to the data of automated hydrostatic levels to minimize the impact on the operating section of the Moscow Metro (from the experience of the organization)

To cite this article: G M Medvedev and E A Khoteev 2021 *J. Phys.: Conf. Ser.* **1928** 012048

View the [article online](#) for updates and enhancements.



**IOP | ebooks™**

Bringing together innovative digital publishing with leading authors from the global scientific community.

Start exploring the collection—download the first chapter of every title for free.

# Experience in effective changing of the tunneling parameters according to the data of automated hydrostatic levels to minimize the impact on the operating section of the Moscow Metro (from the experience of the organization)

G M Medvedev<sup>1,3</sup> and E A Khoteev<sup>2</sup>

<sup>1</sup> Monitoring Department, Scientific and Engineering Center of the Tunnel Association LLC, Moscow, Eniseyskaya ulitsa, 7, stroenie 4, komnata 4, 129344, Russia

<sup>2</sup> Sigma Tau LLC, Moscow, Shosse Entuziastov, 56, stroenie 44, pomescheniye 13, 111123, Russia

<sup>3</sup> medvedev@monitron.ru

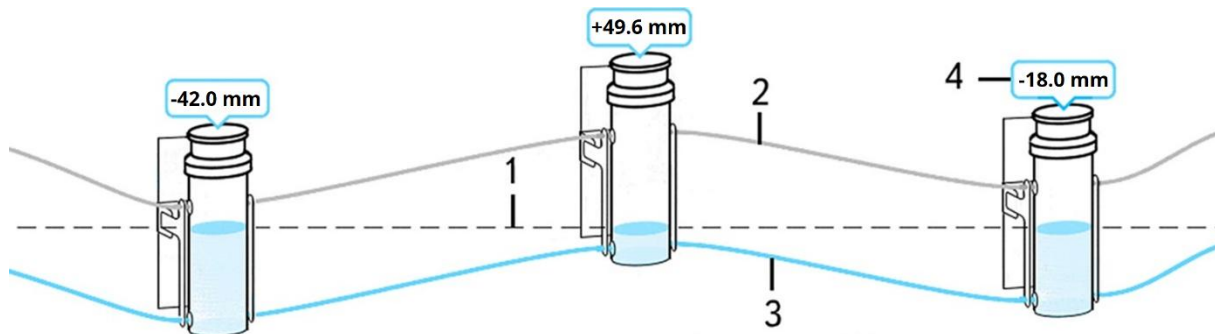
**Abstract.** Due to the intensive development of the underground space of Moscow and the increasing requirements for environmental protection, there is a need for continuous high-precision monitoring of the settlements of existing structures of normal and higher levels of responsibility. Moreover, if points of observation of the structure are located in an open space, then traditional geodetic methods (using optical levels, tacheometers) cannot ensure the continuity of observations (for example, in case of heavy rain, fog, snowfall or smoke). This, in turn, does not allow us to promptly respond to emergencies and take measures to prevent them. The article discusses the experience of automated real-time monitoring using Monitron hydrostatic leveling system to prevent an emergency during the construction of a collector tunnel with a diameter of 4.0 m under one of the Moscow Metro lines.

## 1. Introduction

Automated hydrostatic leveling is a technology for measuring quasi-static settlements, which is used for geotechnical monitoring of buildings and structures of various types [1-5]. Monitron hydrostatic leveling system includes a system of interconnected vessels with liquid level sensors installed on them (figure 1), a data-collecting computer and an internet portal <https://monitron.xyz> provide access to observation data. A feature of Monitron system is the use of innovative optical-electronic liquid level sensors. The advantages of this system over optical levels and tacheometers (manual and automated) are:

- measurements cyclicity (short period between measurements), data from sensors is received 1 time per minute;
- independence of measurement results from weather conditions;
- no need for direct line of sight between sensors;
- fixed measurement accuracy of 0.1 mm, independent of the distance between the sensors and their number.



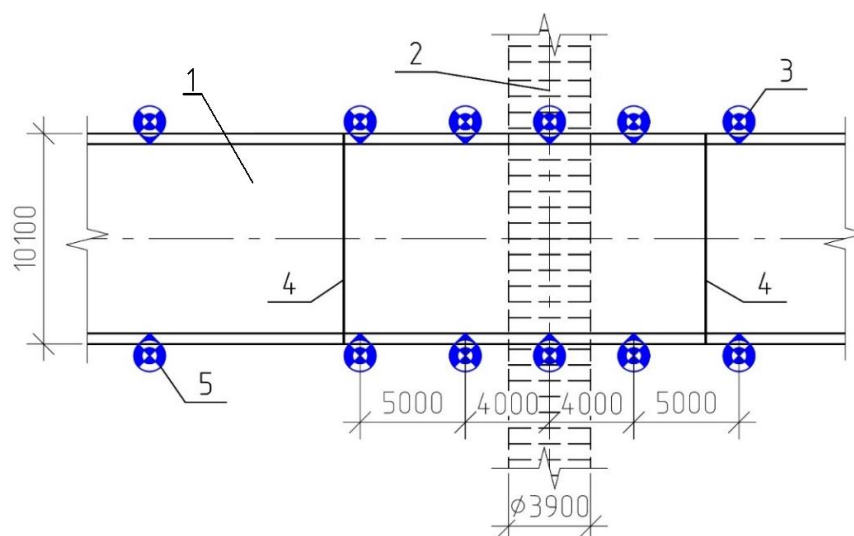


**Figure 1.** How the hydrostatic leveling system works: 1 – hydraulic fluid level; 2 – airline hose; 3 – hydraulic line hose; 4 – change in the high-altitude position of the measuring vessel from the original position.

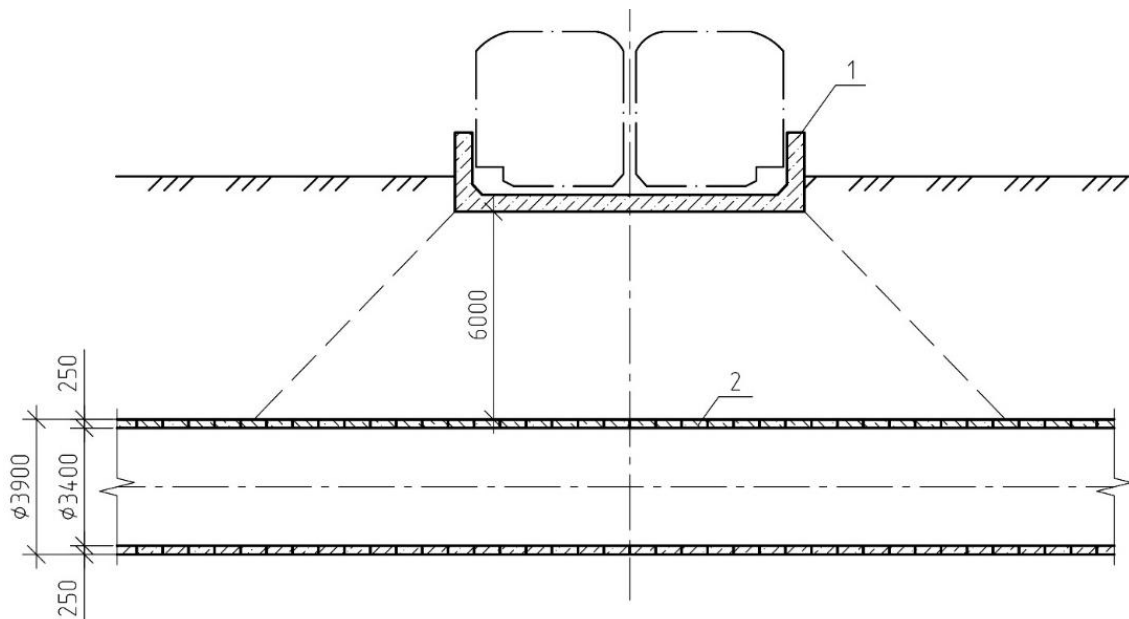
The specified measurements cyclicity is especially important during the construction of tunnels when the tunnel advance rate is about 250 m per month or 8.3 m per day. At the same time, constant observation of the deformations of the monitored objects allows us to promptly change the tunneling parameters, ensuring the safety of existing structures.

Besides, the system has the ability to self-diagnose for damage during operation. The Internet service allows us to configure the automatic generation and distribution of reports to authorized persons, informing via SMS notifications about reaching the threshold deformations.

Considering all the advantages mentioned above, Monitron hydrostatic leveling system was used in the tunneling under an already operating section of the Moscow metro (figure 2) between Filatov lug and Salaryevo stations on the Sokolnicheskaya line. The collector tunnel under construction has the outer and inner diameter of 3.9 and 3.4 m, respectively. The Lovat RME-158 SE earth pressure balance machine (cutterhead diameter is 4.05 m) is used for the excavation. The tunnel is supported by segmental concrete lining and strengthened under the invert of the metro. The segment width is 750 mm. Each ring consists of 6 segments, in the center of which there are grout holes for the grouting of the annular gap. The length of the collector tunnel in the metro technical zone is 50 m. The actual rate of tunneling was 5.6 m/day. The clear distance from the lining of the collector under construction to the metro structures is 6.0 m (figure 3).



**Figure 2.** Plan of the intersection of the collector tunnel under construction (2) with the operating metro section (1), separated by expansion joints (4), location of hydrostatic levels (3), including reference levels (5).



**Figure 3.** Longitudinal section along the axis of the collector tunnel under construction (2) with a cross section of the operating metro section (1).

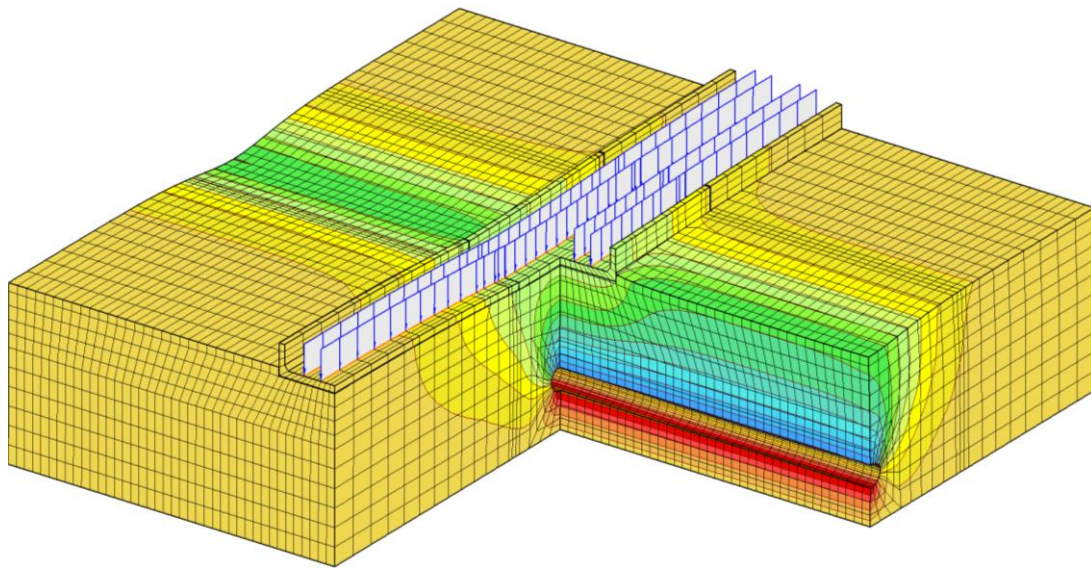
## 2. Application of Monitron hydrostatic leveling system

Taking into account that the actual deformations during tunneling may differ from the design ones, it is advisable to have a digital twin of the structures, which is a sufficiently detailed FEM model of the designed structure, soil and existing structures. Due to the calculation of the digital twin, taking into account the data of hydrostatic levels, it becomes possible to estimate the actual safety factor and predict further changes in the stress-strain state of both structures and soil.

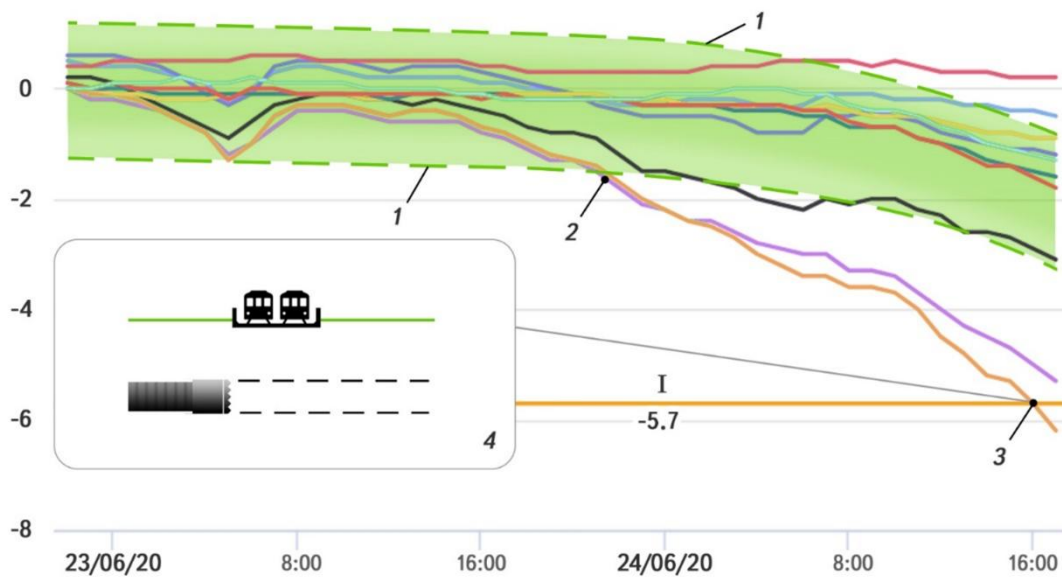
### 2.1. Digital twin

In the present case, a digital twin was developed in ZSoil FEM software (figure 4). The digital twin was calibrated for the design data of the maximum settlement. This allows assigning for each of the hydrostatic leveling sensors an assumed graph of the dependence of the settlement on the position of the TBM with the boundaries of the predicted corridor (see 1 in figure 5), taking into account the accuracy of geotechnical calculations. If the actual settlement graph is out of the predicted corridor, it can be considered a signal for the need to adjust the tunneling parameters or to apply safety measures.

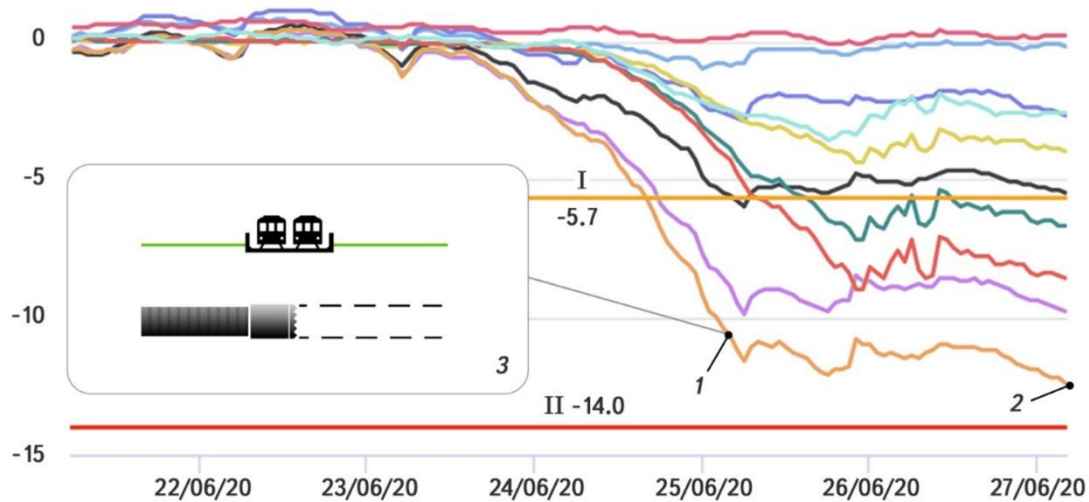
Following the design documentation regarding the construction impact estimation carried out by a third-party organization, a design settlement of 5.4 mm and a threshold settlement of 14.0 mm were assigned. These values were used in <https://monitron.xyz> service as values (see I in figure 5, I and II in figure 6), in a percentage of which SMS messages and emails are automatically sent to all responsible and interested parties (for example, the engineer will receive the first notification at 60% of the threshold, and his manager at 80%).



**Figure 4.** Fragment of a digital twin at the time of completion of tunneling for the design case.



**Figure 5.** Graph of vertical displacements of the existing metro section from 22:00 22-Jun-2020 to 17:00 24-Jun-2020: 1 – boundaries of the predicted settlement corridor of the digital twin for the sensor with the maximum settlement; 2 – the point where the actual settlement goes out of predicted corridor; 3 – maximum settlement of 5.7 mm at 16:00 24-Jun-2020; 4 – approximate TBM position relative to the metro structures at the point on the graph No. 3; I – calculated design settlement (based on the results of the calculation of a third-party organization).



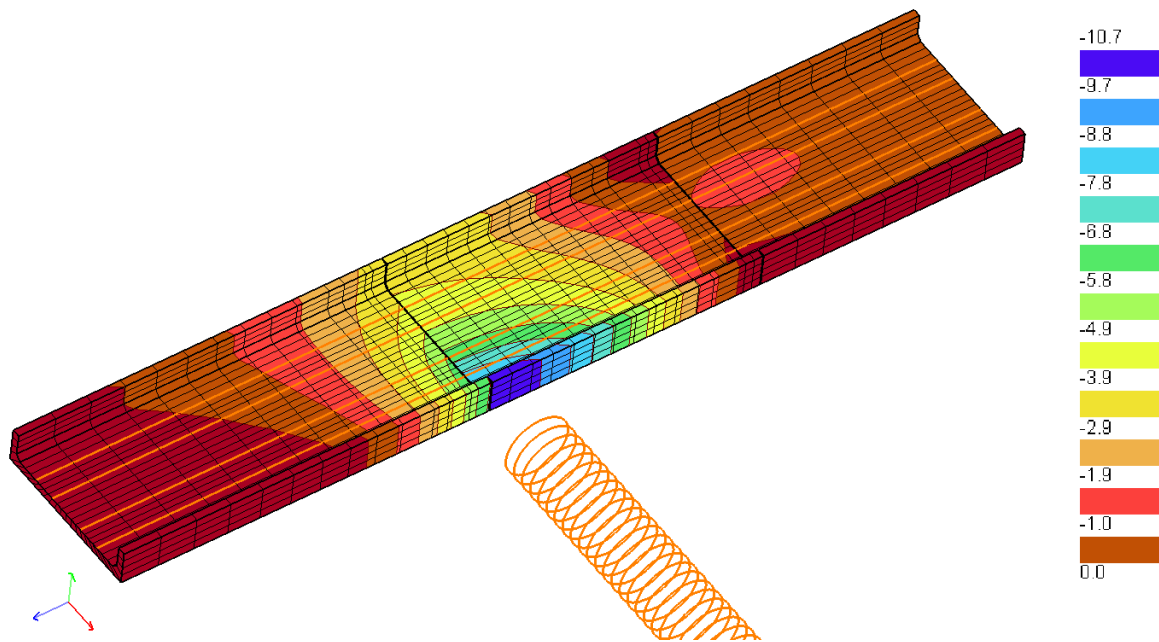
**Figure 6.** Graph of vertical displacements of the existing metro section from 4:00 21-Jun-2020 to 4:00 27-Jun-2020: 1 – maximum settlement of 10.7 mm at 4:00 25-Jun-2020; 2 – maximum settlement of 12.4 mm at 4:00 27-Jun-2020; 3 – approximate TBM position relative to the metro structures at the point on the graph No. 1; I – calculated design settlement (based on the results of the calculation of a third-party organization); II – threshold settlement.

## 2.2. Monitoring results

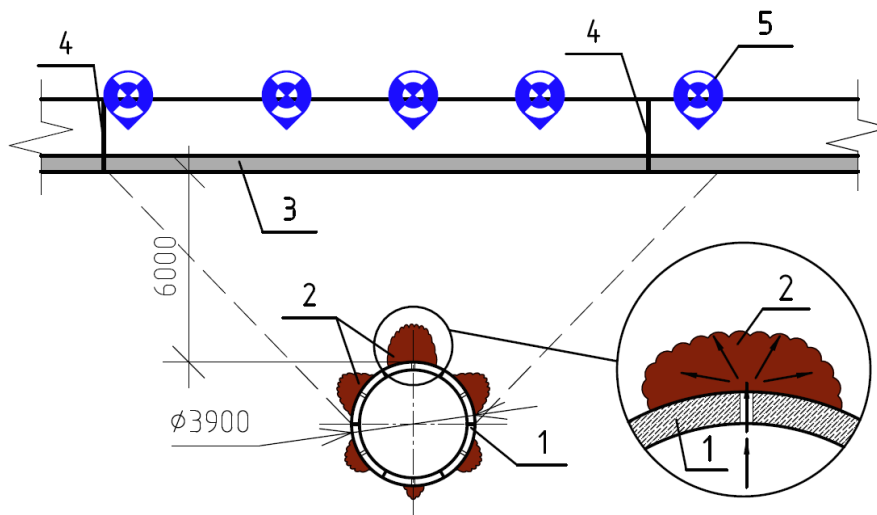
During the collector advance, the results of monitoring of the high-attitude position of the operating metro section at 22:00 on 23-Jun-2020 showed that its settlement reached the boundaries of the predicted corridor of the digital twin (see point 2 in figure 5), which became the first alarm signal about the need to make changes to the tunneling parameters. Upon reaching the design settlement of 5.7 mm (see point 3 in figure 5) the Scientific and Engineering Center of the Tunnel Association, which provided scientific support for the tunneling, sent a letter indicating the need to increase the earth pressure balance to 0.6 bar, and adjust the setting time of the grouting compound to 3 hours.

Further tunneling continued until 4:00 on 25-Jun-2020 showed the insufficiency of the measures taken. With a settlement of 10.7 mm (see point 1 in figure 6 and figure 7) a second letter was sent indicating the need to increase the earth pressure balance to 1.0 bar. Further advance showed that the measure also turned out to be temporary.

Already by 12:00 on 26-Jun-2020 there was a pronounced trend of increasing settlements, which by 4:00 on 27-Jun-2020 had a maximum value of 12.4 mm (see point 2 in figure 6). This corresponds to 87% of the threshold value set by the operating organization. Taking this into account, it was decided to carry out controlled compensation grouting [6-7] from the tunnel under construction to the base of the operating metro section. The essence of the work consisted in injecting grouting compound into each even ring through the holes in the lining blocks (figure 8), up to 4 bar pressure failure.

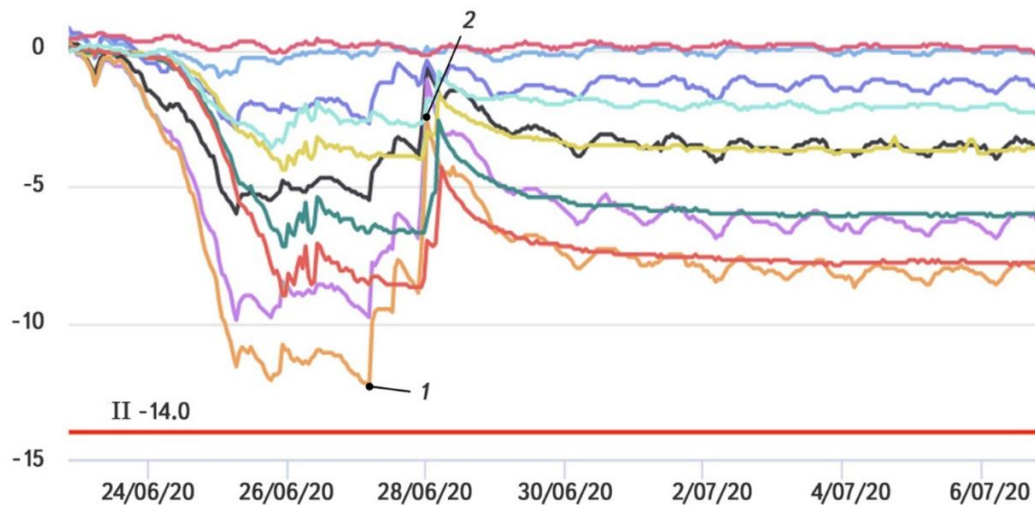


**Figure 7.** Fragment of the digital twin at the time of maximum settlement of the operating metro section of 10.7 mm at 4:00 25-Jun-2020 (see point 1 in figure 6).



**Figure 8.** Scheme of controlled compensation grouting: 1 – tunnel under construction; 2 – injected grouting compound; 3 – operating metro section; 4 – expansion joints; 5 – hydrostatic levels.

The effect of controlled compensation grouting was monitored according to the readings of automated hydrostatic levels. Grouting was stopped on 28-Jun-2020 while the settlement of the sensor, which previously had a maximum value of 12.4 mm (see point 1 in figure 9), was compensated to 2.6 mm (see point 2 in figure 9). The subsequent process of stress relaxation, shrinkage and fluid loss of the grouting compound led to the stabilization of the settlement within 8 days to a maximum value of 8.6 mm (61% of the limiting value).



**Figure 9.** The graph of vertical displacements of the operating metro section for the entire observation period during tunneling: 1 – the start of compensation grouting, maximum settlement of 12.4 mm at 4:00 27-Jun-2020; 2 – compensated settlement from 12.4 mm to 2.6 mm at 0:05 28-Jun-2020); II – threshold settlement.

### 3. Conclusions

Real, proven in practice, preconditions have been created for integrated geotechnical monitoring on the basis of Monitron modern automated hydrostatic levels together with software for creating digital twins. This provides constant monitoring and control over the change in the stress-strain state of buildings and structures under construction or operation during the development of underground space.

When analyzing geotechnical monitoring data, it is necessary to compare the measurement results not with their calculated maximum value, but with the calculated values of deformation for each point of observation, taking into account the current stage of construction. This allows the combined use of Monitron automated hydrostatic levels and the digital twin of the monitoring object.

### References

- [1] Pellissier P F 1965 Hydrostatic leveling systems *IEEE Transactions on Nuclear Science* **12** 19–20
- [2] Meier E, Geiger A, Ingensand H, Licht H, Limpach P, Steiger A and Zwysig R 2010 Hydrostatic Levelling System: measuring at the system limits *J. of App. Geodesy* **4** 91
- [3] Tsvetkov R V, Yepin V V and Shestakov A P 2017 Numerical estimation of various influence factors on a multipoint hydrostatic leveling system *IOP Conf. Ser. Materials Science and Engineering* **208** 012046
- [4] Pospíšil J and Dandoš R 2018 Basic principles of hydrostatic levelling *GeoScience Engineering* **64** 12–21
- [5] Zhang X, Zhang Y, Zhang L, Qiu G and Wei D 2018 Power transmission tower monitoring with hydrostatic leveling system: measurement refinement and performance evaluation *Hindawi Journal of Sensors* **2018** 1–12
- [6] Zertsalov M G, Simutin A N and Aleksandrov A V 2019 Calculated substantiation of controlled compensation grouting for lifting the foundation slab of Zagorsk PSP-2 *Power Technology and Engineering* **52** 512–16
- [7] Bellendir E N, Aleksandrov A V, Zertsalov M G and Simutin A N 2016 Building and structure protection and leveling using compensation grouting technology *Power Technology and Engineering* **50** 142–6